

Development of 72 kV Compact Cubicle Type Gas Insulated Switchgear (C-GIS)

Tatsuro Murakami,
Daiki Takewaki

Keywords C-GIS, Stress analysis, Electric field analysis

Abstract

There has been a recent increased demand for effective use of space by installing substations on the rooftops and basements of buildings and in vacant lots of existing substations. There is, therefore, a demand for more compact and lighter equipment than ever before. To achieve this demand, we developed the 72 kV Compact Cubicle Type Gas Insulated Switchgear (C-GIS) featuring a compact design.

By optimizing the insulation design using electric field analysis and a strength study of tanks and conductors using stress analysis from the basic design stage, we achieved a 20% reduction in volume ratio from our current products. In addition, the 5-panel configuration has been reduced to a 3-panel configuration. The installation space and the total mass reduced to 30% respectively.

1 Preface

The Cubicle type Gas Insulated Switchgear (C-GIS) is a type of major equipment that composes part of substation facilities. It is a combination of module units such as a Vacuum Circuit-Breaker (VCB), Disconnecting Switch (DS), and Earth Switch (ES), all assembled into a box-shaped vessel. It is basically installed in a style of panel alignment. Accordingly, a further compact design is required.

It is, however, necessary to note that there is a trade-off relationship between compact design and insulation performance. To reduce equipment size while maintaining insulation performance, it is indispensable to use an optimized design approach based on high-accuracy insulation design or stress analysis technology.

This paper introduces the outlined product features of the newly developed 72 kV compact C-GIS and various analytical approaches adopted to realize the compact design. It also shows the result of its verification.

2 Ratings and Basic Construction

Table 1 shows the ratings of the developed equipment and **Fig. 1** shows the internal construction and a single-line connection diagram.

3 Outline of Compact Design

To realize the compact design of the C-GIS, the use of a new type VCB unit is indispensable. The VCB, DS, and ES unit are assembled in a packaged unit. By reducing the size of the VCB and DS manipulator, it can be placed in the equipment, and by reducing the size of the Vacuum Interrupter (VI) unit, the height dimensions were reduced. As a result, the volume of this total unit was reduced by approximately 30% compared to the conventional unit. **Fig. 2** shows the basic structure of the new VCB, DS and ES unit.

4 Analysis Technologies

To realize the compact design of the C-GIS, multiple technologies were adopted to analyze various physical factors such as electric fields, stresses, electromagnetic forces, and mechanisms at the time of designing. As an example, insulation design by using the electric field analysis is outlined below.

4.1 Electric Field Analysis

Fig. 3 shows examples of electric field analysis for the new type of VCB, DS, and ES unit. By using three-dimensional Finite Element Method (FEM), setting and detailed modeling of floating

Table 1 Ratings

Ratings of the developed equipment are shown.

(a) C-GIS

Items	Specifications
Rated voltage	72 kV
Rated lightning impulse withstand voltage	350 kV
Rated current	800/1200 A
Rated frequency	50/60 Hz
Rated short-time withstand current	31.5 kA-2 s
Reference pressure (Rated)	SF ₆ 0.12 MPa·G (at 20°C)
Applicable standard	JEM1499-2012

(b) VCB

Items	Specifications
Rated voltage	72 kV
Rated lightning impulse withstand voltage	350 kV
Rated short-time withstand current	31.5 kA-2 s
Rated current	800/1200 A
Rated breaking current	31.5 kA
Breaking time	3 cycles
Operating system	Motor-charged spring operation system
Applicable standard	JEC-2300-2020

(c) DS

Items	Specifications
Rated voltage	72 kV
Rated lightning impulse withstand voltage	350 kV
Rated current	800/1200 A
Switching capability Charging current	1 A
Rated short-time withstand current	31.5 kA-2 s
Operating system	Motor-powered operation
Applicable standard	JEC-2310-2014

(d) ES

Items	Specifications
Rated voltage	72 kV
Rated lightning impulse withstand voltage	350 kV
Rated current	800/1200 A
Rated short-time withstand current	31.5 kA-2 s
Operating system	Manual operation (Motor-powered operation)
Applicable standard	JEC-2310-2014

(e) Maintenance ES

Items	Specifications
Rated voltage	72 kV
Rated lightning impulse withstand voltage	350 kV
Rated current	800/1200 A
Rated short-time withstand current	31.5 kA-2 s
Operating system	Manual operation
Applicable standard	JEC-2310-2014

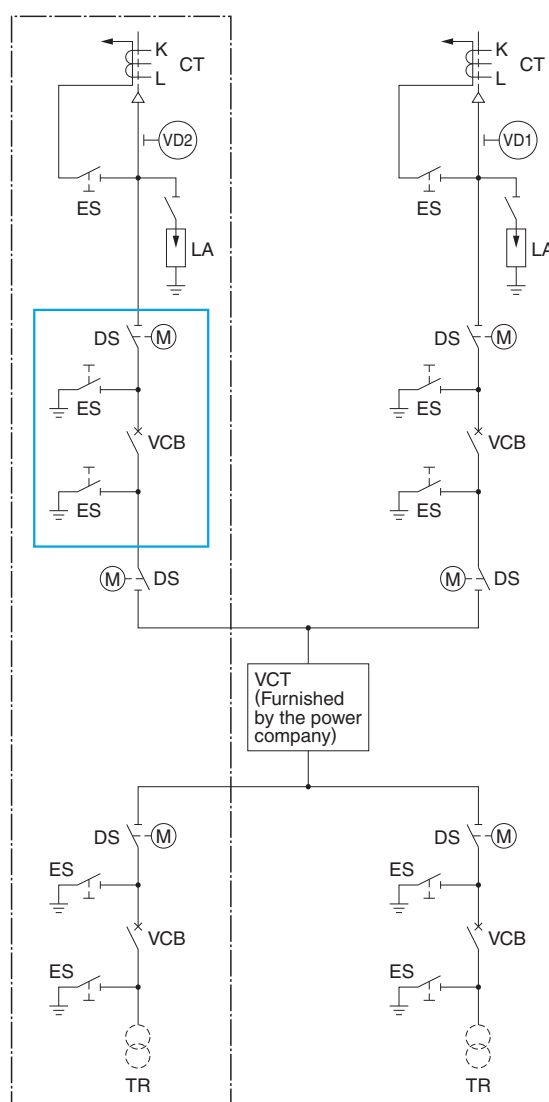
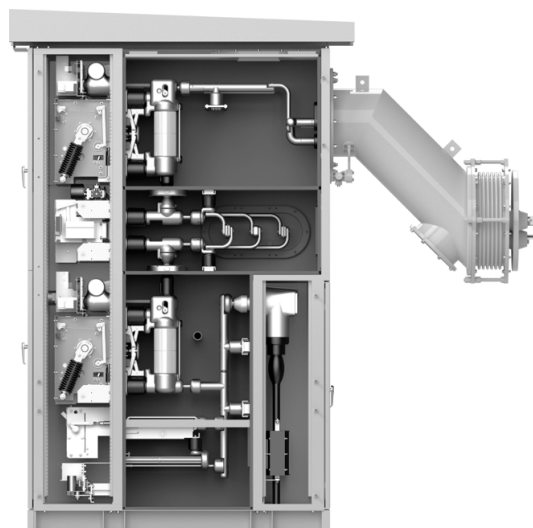

Fig. 1 Internal Construction of Developed Equipment and Single-Line Connection Diagram

The internal construction of the developed equipment and a single-line connection diagram are shown. Devices surrounded by a single-dot chain line are accommodated in a single panel of C-GIS.

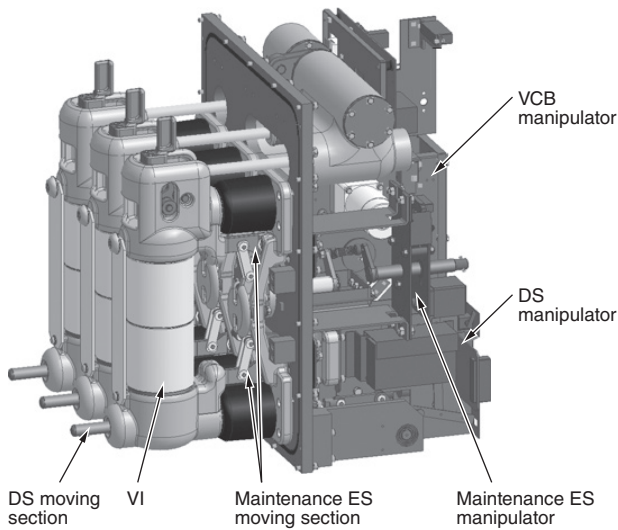
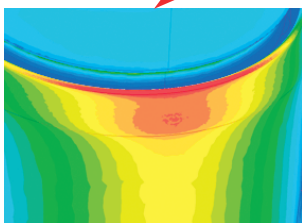
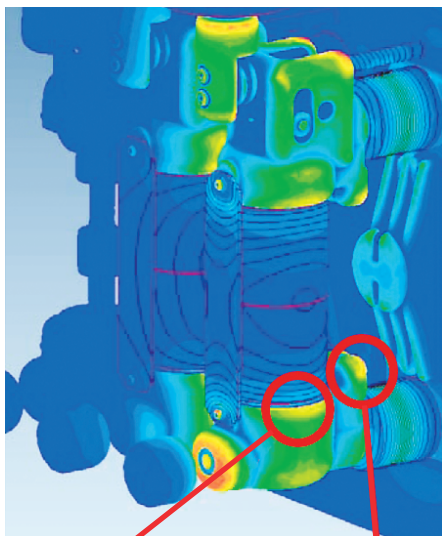
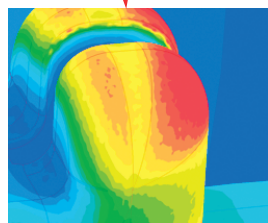

Fig. 2 Basic Structure of New VCB, DS, and ES Unit

Structure of a newly developed VCB, DS, and ES unit is shown. Devices surrounded by a blue frame in Fig. 1 are assembled into a single packaged unit.



(a) VCB conductor



(b) Maintenance ES conductor

Fig. 3 Examples of Electric Field Analysis

The result of electric field analysis for a newly developed VCB, DS, and ES unit is shown.

electrodes (VI mid-shield) were carried out to simulate an actual shape; this was not be able to perform

by a conventional three-dimensional Surface Charge Method (SCM). By this method, values of the electric field were computed for complicated shapes, floats of conductor-end parts, contact parts, as well as sections that may be influenced by the electrodes behind. This was previously difficult to evaluate.

For the evaluation of the analytical result, a factor of the area effect was employed. The area effect is a phenomenon: when the electrode surface area exposed to a high electric field is decreased, the number of weak points (the destruction triggers within this area) is also decreased, and the electric field intensity of insulation breakdown is probabilistically raised as a result. Formerly, it was difficult to evaluate a section, such as a conductor-end part, where a high electric field is locally generated. Accordingly, it was necessary to establish a shape that is practically unnecessary, in such a manner to eliminate an end part of a conductor or enlarge the size of a shape. When an evaluation is performed by implementing the area effect, however, adequate evaluation can be made on VCB conductors and such sections where a high electric field is locally generated, thus attaining an adequate shape.

5 Verification Test

We implemented a series of type tests such as a switching test, withstand voltage test, electrification test, and short-circuit current breaking test stipulated by the JEM and JEC, and favorable results were obtained. In this section, the results of comparison are introduced between the result of lightning impulse voltage withstand test and that of electric field analysis. Fig. 4 shows a situation of withstand voltage test for equipment under test.

Table 2 shows a comparison of results between testing and analysis. A figure of 50% flashover voltage (50%FOV) was obtained from the lightning impulse withstand voltage test and electric field analysis. For the maintenance ES conductors, the result of testing was compared with that of analysis to confirm the adequacy of our designing approach. Since the VCB conductors were tested in the same unit where the maintenance ES is installed, it was impossible to raise the test voltage up to the level of the test result. For this reason, an estimated value of 453 kV or above is specified in the result table.

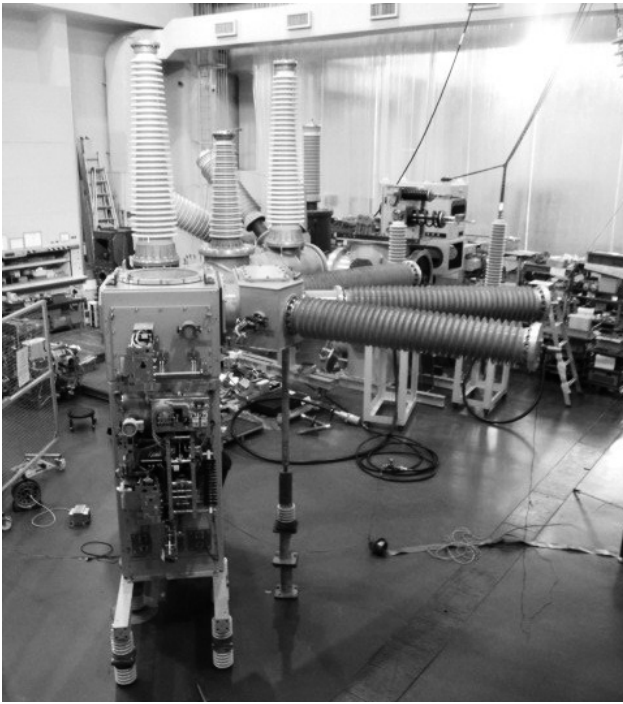

Fig. 4 Situation of Withstand Voltage Test for Equipment under Test

A view of withstand voltage test for equipment under test is shown.

.....

Table 2 Comparison of Results between Testing and Analysis

It is confirmed that the result of testing coincides with that of analysis.

Object	Test result (50%FOV)	Analytical result (In consideration of area effect)
VCB conductor	453 kV or above	665 kV
Maintenance ES conductor	453 kV	420 kV

6 Postscript

We established a design approach in consideration of analysis technologies and area effect to realize the compact design of the C-GIS. For equipment other than those introduced, development of a compact design approach was also carried out for a transformer primary-circuit panel equipped with an exciting current switching DS in order to extend the equipment variation.

The first unit of this C-GIS was delivered in April 2021. This equipment is also applicable to the 84 kV rating that is compatible with the specification of reduced voltage. Toward the future, we will promote further expansion of our product lineups.

· All product and company names mentioned in this paper are the trademarks and/or service marks of their respective owners.