

# Technical Approach to Loss Reduction for Turbine Generators

Takuya Kurasawa,  
Ryota Ishii

Keywords Generator, loss, Electromagnetic field analysis

## Abstract

**Due to growing interest in environmental issues and saving energy, markets call for higher efficiency in electrical generators.**

**To realize such high efficiencies for electrical generators, we have been working on the reduction of iron loss and stray load losses. Since it is difficult to determine the specific area of loss values of iron and stray load losses from measured total loss values, the accurate prediction of such loss values is important. In our development activities, we made electromagnetic field analysis by the three-dimensional (3D) finite element method to grasp locations where losses are generated. In doing so, we explored reasonable measures for loss reduction. By applying the loss reduction method developed through this research, we produced a prototype electrical generator and realized about 20% of loss reduction in a total value of iron loss and stray-load losses.**

## 1 Preface

There is growing interest in environmental issues and saving energy, the markets call for higher efficiency in electrical generators. To meet such market demands, we have been selling a new-type of 4-pole turbine generators since 2014. Its rotor structure was modified from the cylindrical pole type to the salient pole type.

To further improve efficiency and energy saving feature, we have been working on the reduction of losses in 4-pole turbine generators. This paper introduces the result of loss reduction by three-dimensional magnetic field analysis.

## 2 Loss Analysis

To realize high efficiency for an electrical generator, it is very important to estimate losses accurately generated in the integral key parts of the electrical generator.

With regard to iron loss and stray load losses in particular, it is possible to measure the total loss values generated in the entire machine, but it is difficult to determine such values in specific areas and such loss values generated in each key part. Hence, it is important to make prediction of such losses.

Now it is estimated that most of iron loss is generated in the stator core, while stray load losses are generated in a variety of parts that compose the electrical generator. In the case of stray load losses, it is therefore, very difficult to make correct prediction of such values.

Formerly, losses were estimated by using an empirical formula that is based on actual measured values of a similar model generator. By this method, however, it is impossible to apply to cases such as fine shape changes of structural materials. The loss in each part is unclear. For this reason, loss reduction was limited to partial countermeasures such as changing the electrical steel sheets to a higher grade in order to reduce the iron loss.

Recently, with the remarkable progress of the computers, a large-scale loss analysis by the three-dimensional (3D) finite element method became commercialized. For loss analysis, distribution of losses can be made visible. This method is very useful in specifying the locations of the loss generating. In the case of our loss reduction method, we decided to use a loss analysis approach based on the 3D finite element method. In doing so, we specified the loss generating locations and worked on effective measures for loss reduction.

## 2.1 Improvement of Accuracy for Loss Analysis

Accuracy of analysis becomes very important when specifying the loss generating through loss analysis and defining the target locations for loss reduction.

Conventionally, loss analysis was concentrated on places where loss was anticipated to be large and where we confirmed the trends through insufficient because it was impossible to compare with actually measured values.

This time, we tried to grasp the loss distribution by extending the analytical objects to the entire machine and then verified them by comparing the losses with the actual measured values. Some examples are introduced below.

### (1) Stator core

Fig. 1 shows an outline of the magnetic flux inflow into stator cores. Formerly, the research on iron loss in the stator core was limited to investigating loss caused by a magnetic flux flowing in the in-plane direction. At the edge or ventilation ducts of the stator core, a magnetic flux inflow is generated in the direction perpendicular to the stack-up plane of the core. The loss caused by a magnetic flux in the in-plane direction is restrained by splitting eddy currents by the effect of electrical steel sheets. It is, however, impossible to curtail the loss caused by a magnetic flux in a vertical direction. For this reason, a large loss is generated by the vertical magnetic flux. Given the above, it is necessary to perform loss analysis around the core edge and among the ventilation ducts.

Fig. 2 shows a partial analytical model for the

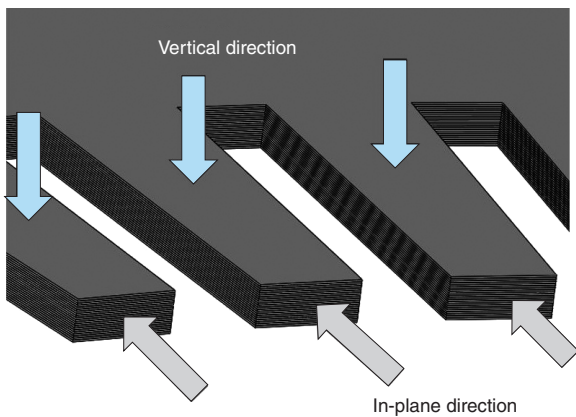

**Fig. 1** Outline of Magnetic Flux Inflow into Stator Cores

The magnetic flux flowing into the stator core is classified into the in-plane flux inflow and the vertical flux inflow. The latter enters vertically into the stacks of electrical steel sheets.

stator core. For this model, analysis was carried out on a partial model where the core edge and ventilation ducts are simulated. As a result, analytical accuracy was improved.

### (2) Rotor pole surface

When we modified the generator structure from the cylindrical type to the salient-pole type, massive poles were adopted for the rotor. In the case of a massive pole, there is no splitting of eddy currents unlike the case of electrical steel sheets. In such a mechanism, loss generation becomes large on the magnetic pole surface. Fig. 3 shows an analytical model of the magnetic pole surface. Formerly, the scale of an analytical model was large and very time-consuming for analysis. For this reason, a partial model was produced for each bolt location and an analytical value was obtained from each model by synthesis. For this time, we used a high speed

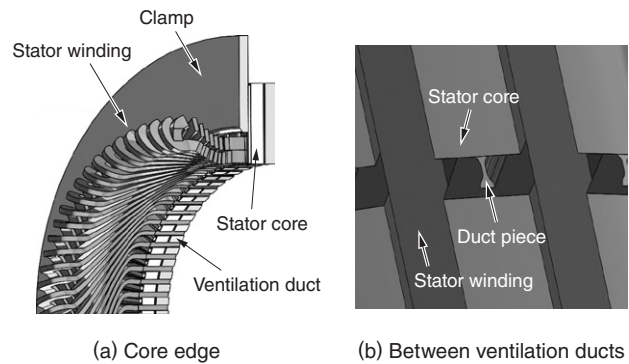

**Fig. 2** Partial Analytical Model for Stator Core

A cross-section of the partial analysis model of the stator core is shown. We conducted our analysis on (a) an edge of stator core and (b) between ventilation ducts. Each simulation was performed separately.

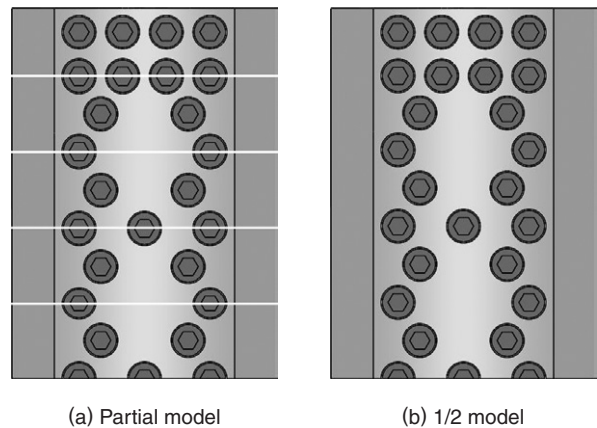

**Fig. 3** Analytical Model of the Magnetic Pole Surface

A partial analytical model and a 1/2 model of the magnetic pole surface are shown. Each model was analyzed to examine any difference.

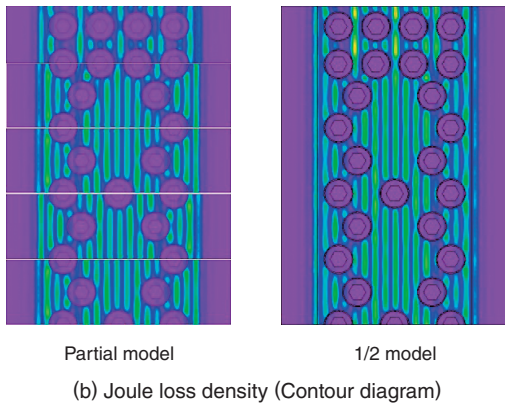
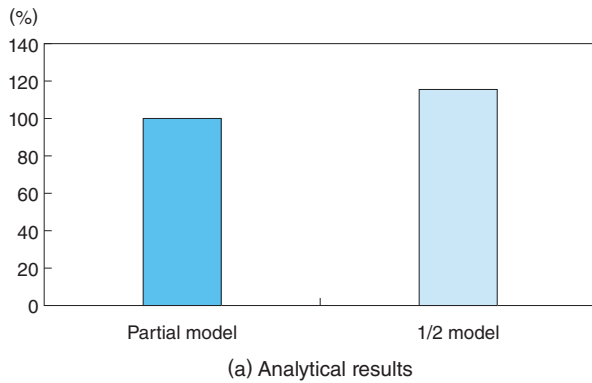

**Fig. 4 Analytical Result for the Magnetic Pole Surface**

Diagram (a) shows the analytical results and diagram (b) shows a contour diagram of joule loss density. In the contour diagram, the display color is changed from purple to red as the joule loss density is increased from low to high.

parallel calculation to reduce the analyzing time. The analysis was carried out by using a 1/2 model of the magnetic pole. **Fig. 4** shows an analytical result for the magnetic pole surface. Calculation on partial models indicates that losses tend to appear in smaller values than the case of a 1/2 model.

In addition to the aforementioned analysis, we conducted another types of analysis as itemized below.

- (1) Stator windings (eddy current loss, circulating current loss)
- (2) Other structural materials (frame, duct pieces, etc.)

## 2.2 Partial Verification

In actual electrical generator production processes, some manufacturing factors can occasionally affect the behavior of the losses. In many cases, such loss generation attributable to manufacturing factors cannot be identified by only the analytical approach. In this case, we did separate partial verifications to obtain the results. The results are introduced below.

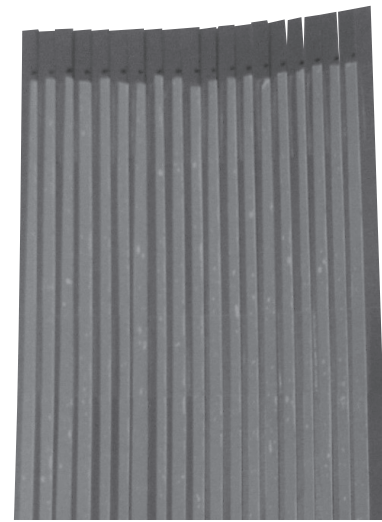

**Fig. 5 Specimen to Verify the Punching Effect (5mm Wide)**

A specimen for verifying the effect of surface distortion by the punching process is shown. Verification work was carried out on multiple specimens with the different width sizes like 5mm through 100mm. We tooled samples and tested.

Electrical steel sheets used for stator cores are manufactured by a punching process. As a result, there can be surface distortion and residual stresses around the punched surface.

The electrical steel sheets show that when the stress is exerted on the surface of the sheet, the characteristics (magnetic one or iron loss) will be changed. It initiates the deterioration of the magnetic characteristics and increases iron loss. Such an increase in iron loss due to surface distortion caused at the time of the punching process is difficult to specify by using the analysis method. As such, we verified this matter through basic experiments.

**Fig. 5** shows a specimen to verify the punching effect. We made multiple specimens of single electrical steel sheets with the different width sizes like 5mm through 100mm. With each specimen, we measured B-H curves and iron loss curves through measurements.

**Fig. 6** shows a verification result regarding the effect of surface distortion caused by punching process. When the punching width is narrower, or when the stress-exerted area is wide, effects by punching process tends to be larger. This leads to the deterioration of magnetic characteristics and an increase in iron loss. Based on the data obtained from the verification results, we improved the analytical accuracy level with due consideration of the effect of iron loss increased by the manufacturing factors.

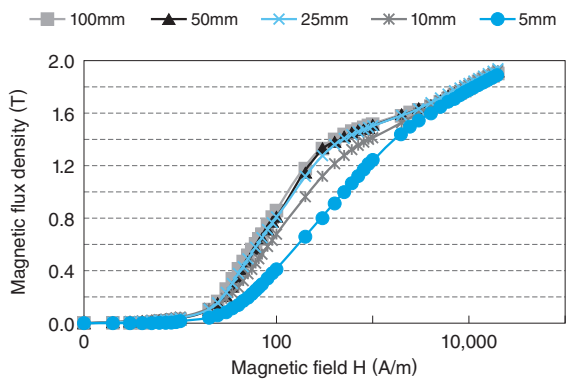

(a) B-H curves

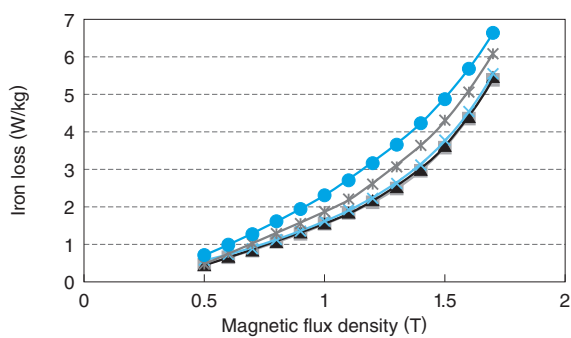

(b) Iron loss curves

**Fig. 6** Verification Result Regarding the Effect of Surface Distortion Caused by Punching Process

The B-H and iron loss curves are shown. These were obtained from the verification of influence caused by distortion at the time of punching. We confirmed the presence of deterioration in magnetic characteristics and an increase in iron loss caused as a result of influence by punching process.

The stator iron core is divided in the circumferential direction due to size constraints. It is manufactured by stacking the electrical steel sheets. For this reason, a gap called a segment gap occurs between the divided electrical steel sheets. Since the magnetic flux passing through the iron core passes through the electrical steel sheets in the stacking direction avoiding the segment gap, the magnetic flux flows perpendicularly to the electrical steel sheets and the loss increases. Since this part is difficult to evaluate in the analysis, a simple stator iron core model was made, and the analysis accuracy was confirmed by separately verifying the effect by stacking up the stator cores. Fig. 7 shows a stator iron core sample for verifying the effects of stacking the stator iron cores.

### 2.3 Comparison with Measured Results

Fig. 8 shows a result of the analysis and actual measurements on conventional structures.

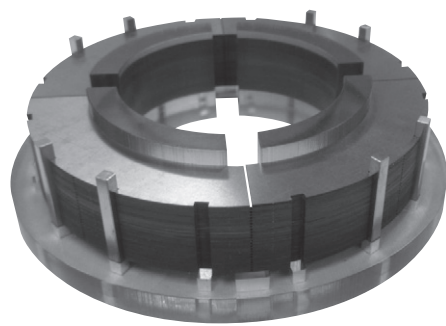

**Fig. 7** Stator Iron Core Sample for Verifying the Effects of Stacking the Stator Iron Cores

Stator Iron Core Sample for Verifying the Effects of Stacking the Stator Iron Cores is shown. This verification was carried out by changing the method of producing the core lamination stacks and evaluating the resultant influence.

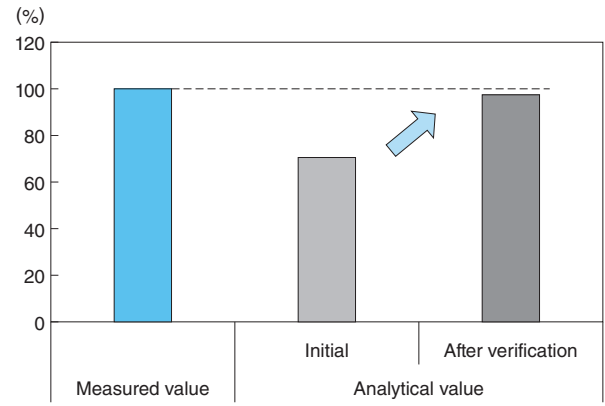
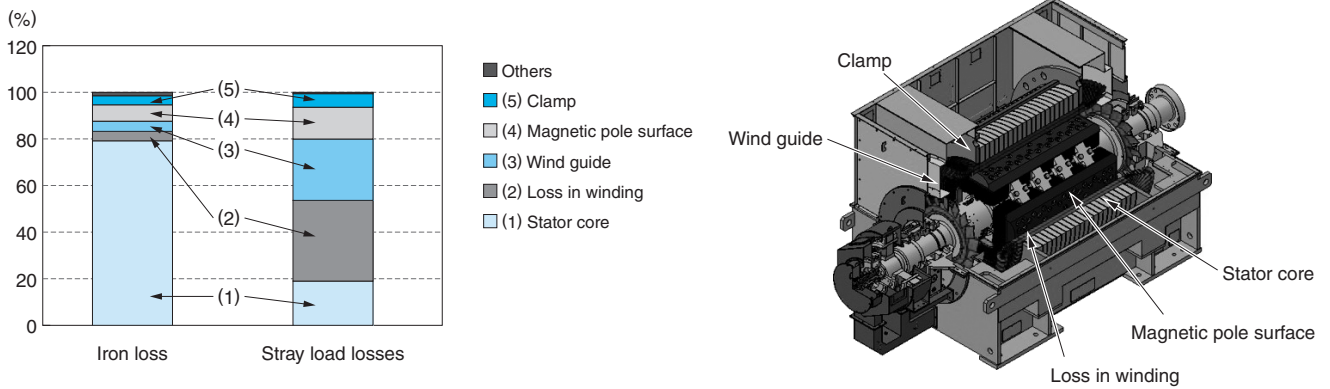

**Fig. 8** Result of Analysis and Actual Measurements on Conventional Structures

Regarding the analytical values and actual measured values obtained from conventional structures. The results of investigation are shown. These were obtained before and after the verification of analytical accuracy.

The graph is shown a rate where measured values are assumed as 100%. At the initial stage, when we compared analytical values and measured values, there was a difference of about 30%. With the improvement of analytical accuracy level, the analysis results became closer to the measured values.

There is a possibility of any big change on the conventional design structure like the structure design change or change of material to be used may influence the analytical accuracy. We view that the current analytical accuracy level is enough to determine the trend in loss reduction, and we continued to work on finding the areas for loss reduction and exploring measures to reduce such losses by using the analysis.



**Fig. 9** Contents of Iron Loss and Stray Load Losses in Conventional Design Structures

Each detail of iron loss and stray load losses in conventional design structures is shown. The graph shows the rate under the condition the analytical values on conventional structure design as 100%.

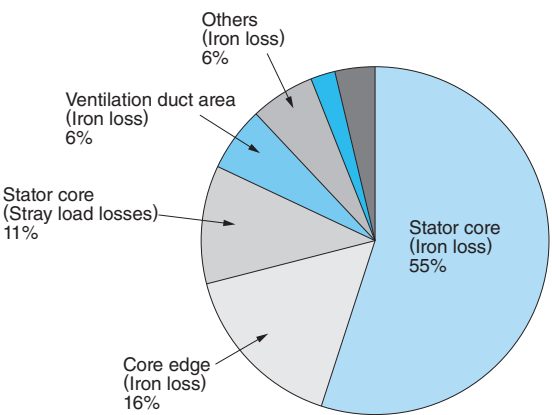

**Fig. 10** Contents of Losses Identified from Stator Core Analysis

The details of losses from stator core analysis are shown.

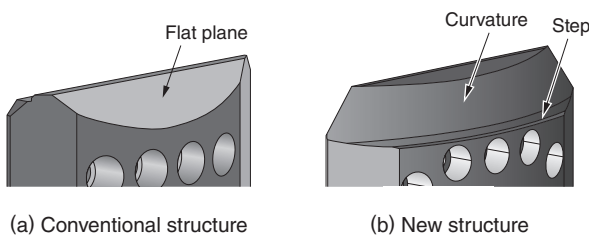

**Fig. 11** Pole Edge Shapes before and after the Study on Loss Reduction

Magnetic pole edge shapes are shown before and after the study on the loss reduction. In the case of a new structure design, loss reduction was realized by making the shape of edge parts into the rounded shape and providing a step.

### 3 Investigation into Loss Reduction

**Fig. 9** shows the contents of iron loss and stray load losses in conventional design structures. According to these results of analysis, we clarified the higher rate of loss in the order of (1) stator core, (2) loss in winding, (3) wind guide, (4) magnetic pole surface, and (5) clamp. Based on the results, we worked on loss reduction measures in the areas where the losses are large. Here, we would like to show some specific sample of our loss reduction measures.

As an example of our study on the loss reduction, we show a method to reduce in-plane eddy current loss at the edge part of the stator core. **Fig. 10** shows the contents of losses identified from stator core analysis. Regarding the losses around the edge parts of the stator core at no load, the rate of losses is large. It amounts to 16% of total losses

in the stator core. As described earlier, there is a vertical flux inflow against the surface of the stator core adjacent to the core edge and this magnetic flux is a cause of an increase in losses. Most of iron loss is caused by leakage flux from the rotor poles. Accordingly, this loss can be reduced if leakage flux from magnetic poles can be reduced. As such, we investigated a method to decrease leakage flux from magnetic poles of the rotor.

**Fig. 11** shows pole edge shapes before and after the study on loss reduction. In our conventional approach, in view of easy processing, we adopted the pole edge structure design as a cutting-off shape in a flat state. After this time study, we changed the shape at the pole edge part to be a curved surface.

In addition, a step was newly provided between the magnetic pole surfaces. The design change to a curved one and a provision of the step resulted in the increase of air clearance in the iron core (rather than in the conventional design). In doing so, we

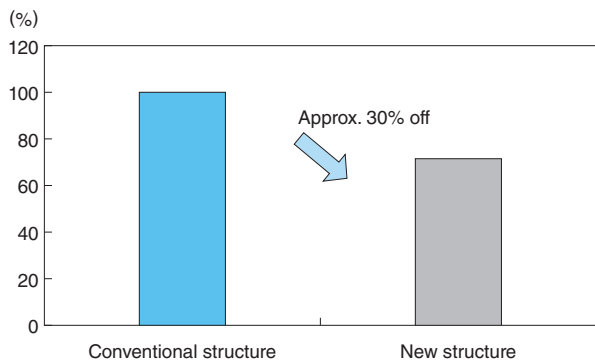

**Fig. 12** Result of Pole Edge Analysis before and after the Study on Loss Reduction

The result of pole edge analysis is shown before and after the study on loss reduction.

aimed to increase the magnetic reluctance and suppress the leakage magnetic flux.

**Fig. 12** shows a result of the pole edge analysis before and after the study on loss reduction. The graph shows the rate of loss reduction under the condition the analytical value of a conventional structure to be 100%. The analytical result of loss values in conventional structures indicates that in-place eddy current loss around the core edge part of a new structure has been reduced by approximately 30%.

Further, we worked hard to reduce losses for other structural areas where losses are large by studying and reviewing the loss reduction methods in a similar manner.

#### 4 Comparison with Measured Results

We produced a prototype based on the method of loss reduction and verification was carried out on an actual prototype machine. Since it was difficult to measure losses at each section of the actual machine, we arranged the flux measuring search coils and hall elements on the stator core in order to confirm the validity of our analysis. The measured results by using the prototype is introduced below.

**Fig. 13** shows design values and the measured results before and after the investigation on the loss reduction. As a result of our measures on loss reduction, we could confirm that a total of iron loss and stray load losses is reduced by about 20% compared with conventional structure design.

Regarding the measurement of magnetic flux density performed to confirm the validity of our analysis, the measured results using the hall elements

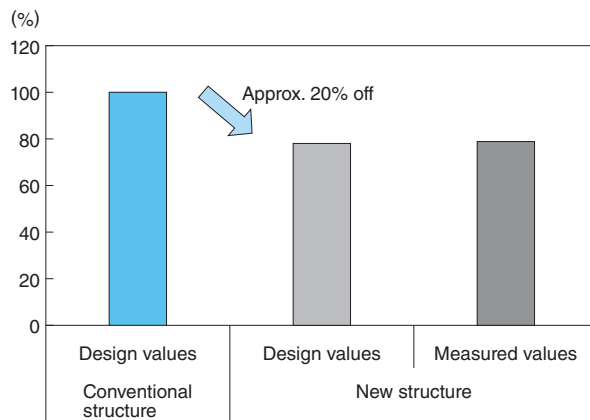

**Fig. 13** Design Values and Measured Results before and after the Investigation on Loss Reduction

Design values and measured results are shown before and after the investigation on loss reduction. Loss values in the graph show a total of iron loss and stray load losses.

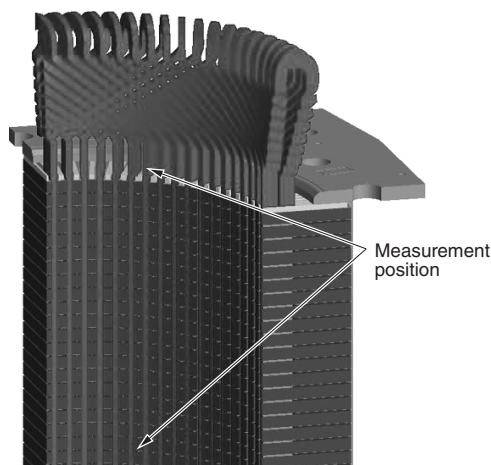

**Fig. 14** Measurement Positions by Hall Elements

Measurement positions by using hall elements are shown. Each hall element was placed on the edge of the stator core and on the inner diameter side.

are introduced below. **Fig. 14** shows the measurement positions by the hall elements. During measurement, the hall elements were respectively placed on the edge of the stator core and on the inner diameter side. **Fig. 15** shows the results of magnetic flux density analysis and measurements. Under the no-load condition and in the state of 3-phase short-circuiting, the result of measurements indicates very similar results between analytical values and measured values. Similar to the aforementioned results, values of flux density measured with hall elements and search coils distributed in other sections also showed similar results between the analytical values and measured values. Judging from the above facts, it is concluded that a respectable simulation

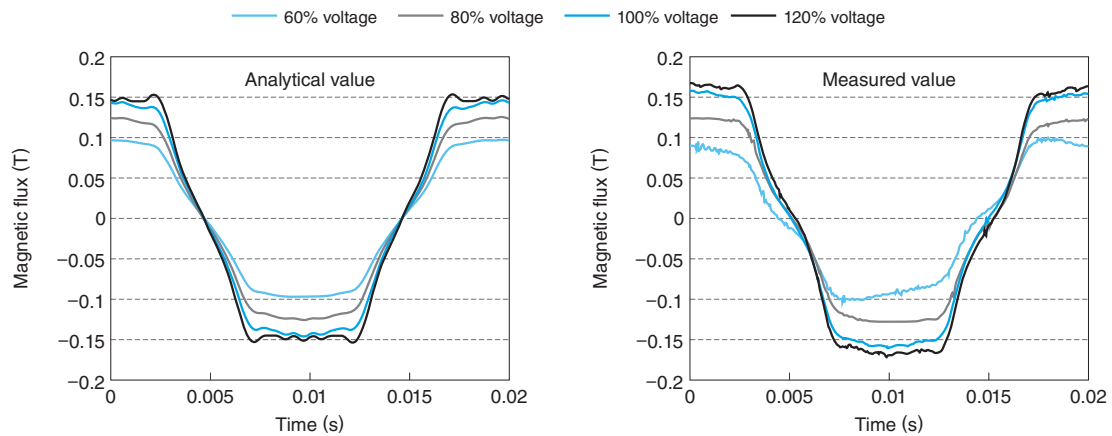

(a) Magnetic flux density at the core edge (under no-load condition)

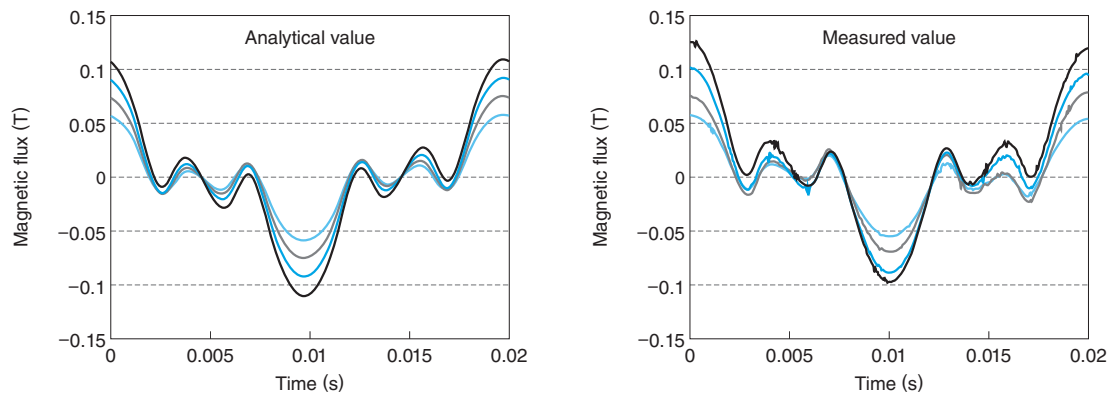

(b) Magnetic flux density at the core edge (under 3-phase short-circuited condition)

**Fig. 15 Results of Magnetic Flux Density Analysis and Measurements**

The results of magnetic flux density analysis and the measurements are shown. The results of analysis are shown. The analysis was made in the same positions where the magnetic flux density was measured by using hall elements attached to the edge part of the stator core.

was made through the analysis of the magnetic flux which is a major factor of loss generation. We consider that our analysis sufficiently grasps the trends of loss generation and its current practical level.

## 5 Postscript

As a result of our study on loss reduction, we realized reduction of iron loss and stray load losses

by about 20% compared with conventional structure design. In the future, we will continue to introduce the most advanced technologies of analysis to further improve analysis accuracy. In doing so, we would like to achieve higher efficiency.

• All product and company names mentioned in this paper are the trademarks and/or service marks of their respective owners.