

# Double Converter

Takahiro Harada,  
Hidenobu Kusumoto

**Keywords** Energy saving, Constant voltage control, IGBT, PWM control

## Abstract

Conventional DC traction power supply systems have employed a system where either of the following occurs: diode rectifiers and regeneration inverters are combined, or regenerative power is consumed in rheostats with diode rectifiers, or regenerative power is stored in battery elements for resource recovery of energy. The double converter is an integrated facility where thyristor rectifiers and IGBT inverters are accommodated and is intended to simplify substation facilities through saving space by sharing AC circuit-breakers, DC high-speed circuit-breakers, and transformers.

Since thyristor rectifiers have been additionally adopted, constant control of the DC output voltage is possible. Still more, it is possible to use output voltage regulation characteristics like diodes. Since IGBT inverters are adopted, harmonics can be suppressed and external filters can therefore be omitted. As a result, improved high-speed response characteristics and high efficiency are available. In so doing, we have eliminated the weak points of conventional inverters.

## 1 Preface

Electric railways can be classified into DC traction power supply systems and AC traction power supply systems. Electric railway trains are driven by motors that gain power from the overhead catenary, the third rail, or the power rail. When train vehicles decelerate to a stop, regeneration brakes are used. Electric power regenerated by these brakes is then supplied to other train vehicles. When regeneration brakes are used, vehicles can reduce the use of mechanical brakes and the wear of the brake shoes can be reduced. The effective utilization of regenerated power can contribute to energy saving.

Generally in DC traction power supply systems, the diode rectifiers for converting AC power into DC have been widely used. As fixed installation facilities for absorbing surplus power from vehicles, we have delivered various kinds of equipment such as regeneration inverters (a system for returning DC power to AC side), the KAISEI PLUS (a system for consuming surplus power in rheostats), and CAPAPOST (capacitor type power charge-discharge system). These products have been widely and frequently adopted by many customers at home and abroad.

This paper introduces a newly developed double converter system which combines the functions of both rectifier and regeneration inverter.

## 2 Outline of the DC Traction Power Supply System

Fig. 1 shows a configuration of the DC traction power supply system equipped with regeneration

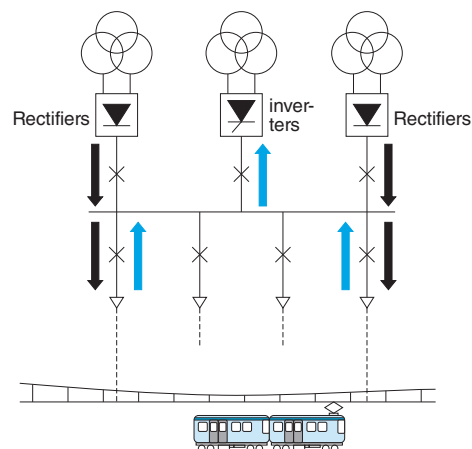

**Fig. 1** Configuration of DC Traction Power Supply System Equipped with Regeneration Inverters

In this configuration, rectifiers and inverters are separately installed.

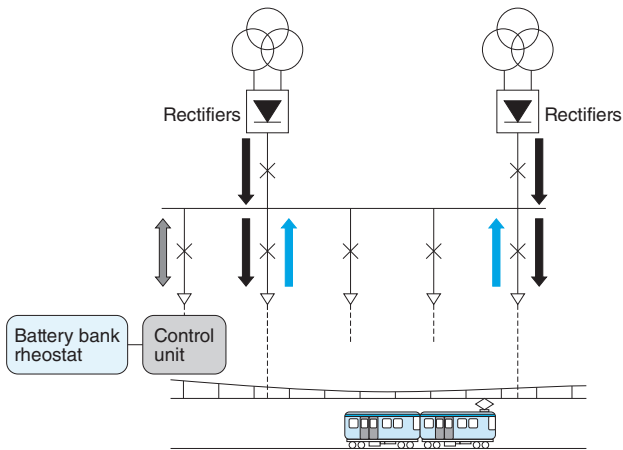

**Fig. 2** Configuration of DC Traction Power Supply System Equipped with Battery Banks and Rheostats

Surplus regenerated power is thermally consumed at the rheostats that are installed in ground facilities, or charged in a battery bank and then consumed as required.

inverters. Fig. 2 shows a configuration of the DC traction power supply system equipped with capacitor banks and rheostats. These DC power feeding substations had the separate arrangement of installations of rectifiers to feed power to train vehicles and facilities to absorb excess power. In order to realize space-saving, simple facility, and reduction of initial investment cost, we have developed the double converter system where rectifiers to supply power and regeneration inverters to absorb excess power are combined.

### 3 Double Converter

#### 3.1 Outline of the System

In the case of conventional diode rectifiers, the feeder voltage varies at a specific rate according to the load factor of vehicles. In addition, at the time of dynamic braking by the vehicles, the feeder voltage is raised by the effect of regenerative power returned from the vehicles. Since conventional regeneration inverters used thyristors, generation of harmonics and low efficiency had been their faults.

The double converter introduced in this paper comes in a combination of thyristor rectifiers and IGBT inverters. This equipment can be applied to both existing and newly installed railway lines and can regulate feeder voltage according to the load and maintain the feeder voltage at a specified level.

Fig. 3 shows a system configuration of the double converter and Table 1 shows the basic specifications of the double converter.

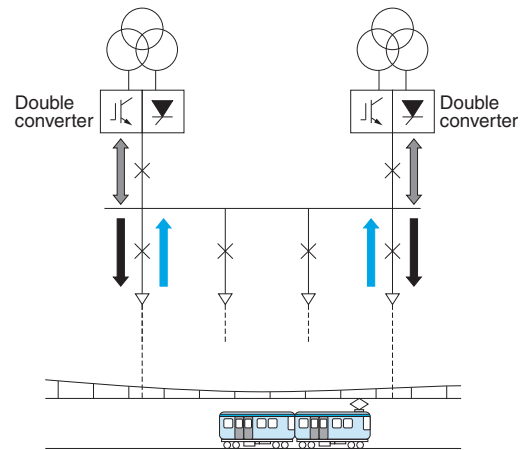

**Fig. 3** System Configuration of Double Converter

This figure shows a DC traction power supply system configuration where the double converter is introduced. The double converter is performing a parallel operation.

**Table 1** Basic Specifications of Double Converter

Functional characteristics of rectifiers and inverters are shown.

Item	Rectifier specifications	Inverter specifications
Circuit configuration	Thyristor phase-controlled rectifiers	PWM converter
Capacity (kW)	2000	500
Rated DC voltage (V)	750	750
Overload durability	100% continuous, 150% for 2 hours, 300% for 1 minute	100% continuous, 300% for 1 minute
Rated voltage setting range (V)	600~775	620~850 (Setting adjustable in 1V unit)
Max. DC voltage (V)	900	900
Rated AC voltage (V)	640	460
Frequency (Hz)	50/60	50/60
Cooling system	Self-cooled	Forced-air-cooled
Environmental conditions	Temperature: -5~40°C Relative humidity: 15~95% Altitude: 1000m or below	
Applicable standards	IEC, JEC	

#### 3.2 Functions and Features of Double Converter

Fig. 4 shows a single-line diagram for the double converter and Fig. 5 shows its voltage and current characteristics. Since the double converter comes in a configuration where AC circuit-breakers, DC high-speed circuit-breakers, and transformers are shared by thyristor rectifiers and IGBT inverters, such a configuration can contribute to saving installation space.

The double converter supplies power from the

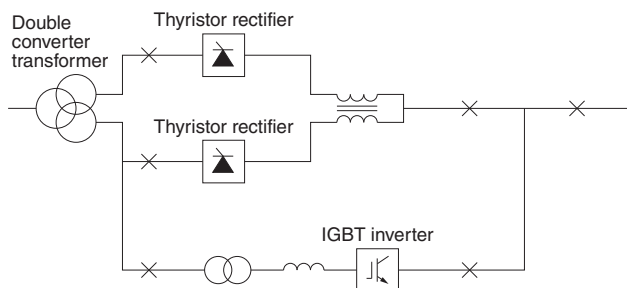

**Fig. 4** Single-Line Connection Diagram for Double Converter

A general configuration of the double converter is shown.

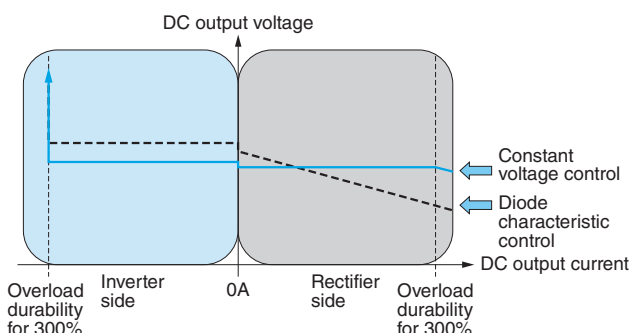

**Fig. 5** Voltage and Current Characteristics of Double Converter

The voltage and current characteristics of rectifiers and inverters are shown.

thyristor rectifiers at the time of the vehicle's running power. The output voltage can be regulated within the specified range at a constant rate according to the load like performance of diodes. In facilities where diode rectifiers are already introduced, system operation can therefore be performed in diode mode so that an adequate load balance can be maintained with the neighboring substation. For a newly installed track, voltage-constant control is carried out. In such a case, the following advantages can be expected:

- (1) Reduction of power loss at the time of power feeding
- (2) Reduction of leakage current by relieving the voltage difference between substations
- (3) Eliminate the voltage limiting device by reducing the touch voltage required by IEC Standard

For conventionally used thyristor type inverters, a circulating current was flowed between rectifiers in terms of response speed in order to follow up on a sharply rising regeneration current from vehicles. In addition, a complicated control circuit was needed so that circulating and regenerative currents observed.

Since IGBTs are used for this time, the aforementioned circulating current to be led between rectifiers need not be taken into consideration and the response speed has been reduced to within 1ms as a result. Still more, as a result of the adoption of IGBT system and PWM control system, the generation of harmonics has been reduced, thus eliminating external filters.

As an outstanding feature of the Meiden Double Converter, only the functions of the faulty device can be separated if thyristor rectifiers or IGBT inverters should encounter any malfunction. Functional separation can enhance usability and such a feature contributes to the improvement of reliability in electric railway power supply systems.

In addition, the following additional functions can be itemized:

- (1) Substation voltage compensation function

This is a function to adjust inverter operation setup values in conjunction with variations in incoming voltage.

- (2) Detected voltage correcting function

This is a function to compensate for a voltage drop caused by conduct wire resistance so that the inverter operates correctly.

- (3) Real load testing function

This is a function to simulate regeneration pattern testing as the result of the updating of the train operation diagram.

### 3.3 Human Machine Interface (HMI)

Since the double converter is equipped with a color LCD touch screen panel, various setup changes such as equipment RUN · STOP can be made with the touch panel. In addition, equipment status monitoring, operation log check, and measurement of voltages and currents can be carried out. If a fault occurs in the system, we installed the collective display fault indicators installed in addition to the LCD. This is to help an operator to immediately assess the situation of equipment immediately and check the faults.

## 4 Electro-Magnetic Compatibility (EMC) Test

According to the EMC test programs stipulated by IEC 62236, electrical facilities for railway systems are obligated to undergo the durability test on equipment against any external electric waves. The IEC 62236 is composed of -1 (General), -2 (Emission

**Table 2 EMC Test Items**

This table shows the EMC test items stipulated by the IEC 62236-5 Standard.

No.	Test items	Test specifications	Applicable standards
1	Emmission Test		
1.1	Conducted emission (AC mains ports)	0.5dB, AV (5.33340MHz, N)	IEC 61000-6-4 Table clause 2.1
1.2	Conducted emission (Telecommunication ports)	N/A	IEC 61000-6-4 Table clause 3.1
1.3	Radiated emission (30-1000MHz)		IEC 61000-6-4 Table 1.1
1.4	Radiated emission (1000-MHz)		IEC 61000-6-4 Table clause 1.4
2	Immunity Test		
2.1	Electrostatic discharge	±6kV, ±8kV	IEC 61000-4-2
2.2	Radio-frequency electromagnetic field, amplitude modulated	80MHz-1000MHz 10V/m (r.m.s.) 80% AM, 1kHz	IEC 61000-4-3
2.3	Radio-frequency electromagnetic field, from digital mobile Telephones	800MHz-1000MHz 20V/m (r.m.s.) 1400MHz-2100MHz 10V/m (r.m.s.) 2100MHz-2500MHz 5V/m (r.m.s.) 80% AM, 1kHz	IEC 61000-4-3
2.4	Fast transients	±4kV 5/50ns 5kHz (AC, DC powr port)	IEC 61000-4-4
2.5	Surges	1, 2/50µs AC power port ±4kV (line to line) ±2kV (line to earth) DC power port ±2kV (line to line) ±1kV (line to earth)	IEC 61000-4-5
2.6	Radio-frequency common mode	AC, DC power port 0, 15MHz-80MHz 10V (r.m.s.) 80% AM, 1kHz	IEC 61000-4-6
2.7	Power-frequency magnetic field	16, 7Hz; 50/60Hz 100A/m (r.m.s.)	IEC 61000-4-8

of the whole railway system to the outside world), -3-1 (Rolling stock – Train and complete vehicle), -3-2 (Rolling stock – Apparatus), -4 (Emission and immunity of the signaling and telecommunications apparatus), -5 (Emission and immunity of fixed power supply installations and apparatus). For the system introduced in this paper, a series of testing has been conducted in accordance with IEC 62236-1, -2, and -5. The method of practical testing conformed to IEC 61000. **Table 2** shows the EMC test items. As a result of testing, the equipment passed all of the test items.

## 5 Postscript

For the double converter, various systems had been proposed, such as a system where thyristors are combined in both directions, a bi-directional current-carrying system under the PWM control by IGBTs, and a system where IGBTs and diodes are combined. If this system is viewed in a single unit of

power supply system, a significant challenge remains of the initial investment cost.

If this system is viewed in a total perspective as a DC railway power supply system, it can realize the resource recovery of excess regenerated power, improvement of vehicle riding comfort, and reduction of vehicle maintenance cost. In addition, the adoption of the double converter introduced in this paper for all railway systems is expected to result in the reduction of total vehicle weight and vehicle unit cost because the line-to-ground voltage suppressing installations can be eliminated due to the reduction of the touch voltage and the braking power can be handled by the ground facilities.

In closing, we would like to thank all individuals concerned for their kind cooperation and valuable suggestions for the supply of the Meiden products.

• All product and company names mentioned in this paper are the trademarks and/or service marks of their respective owners.